

NOTES  
1+3

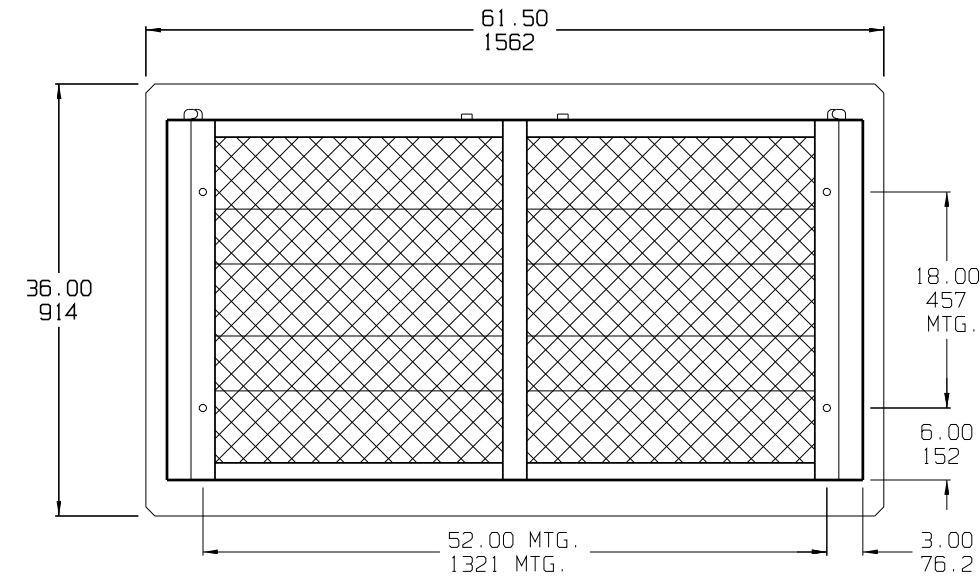
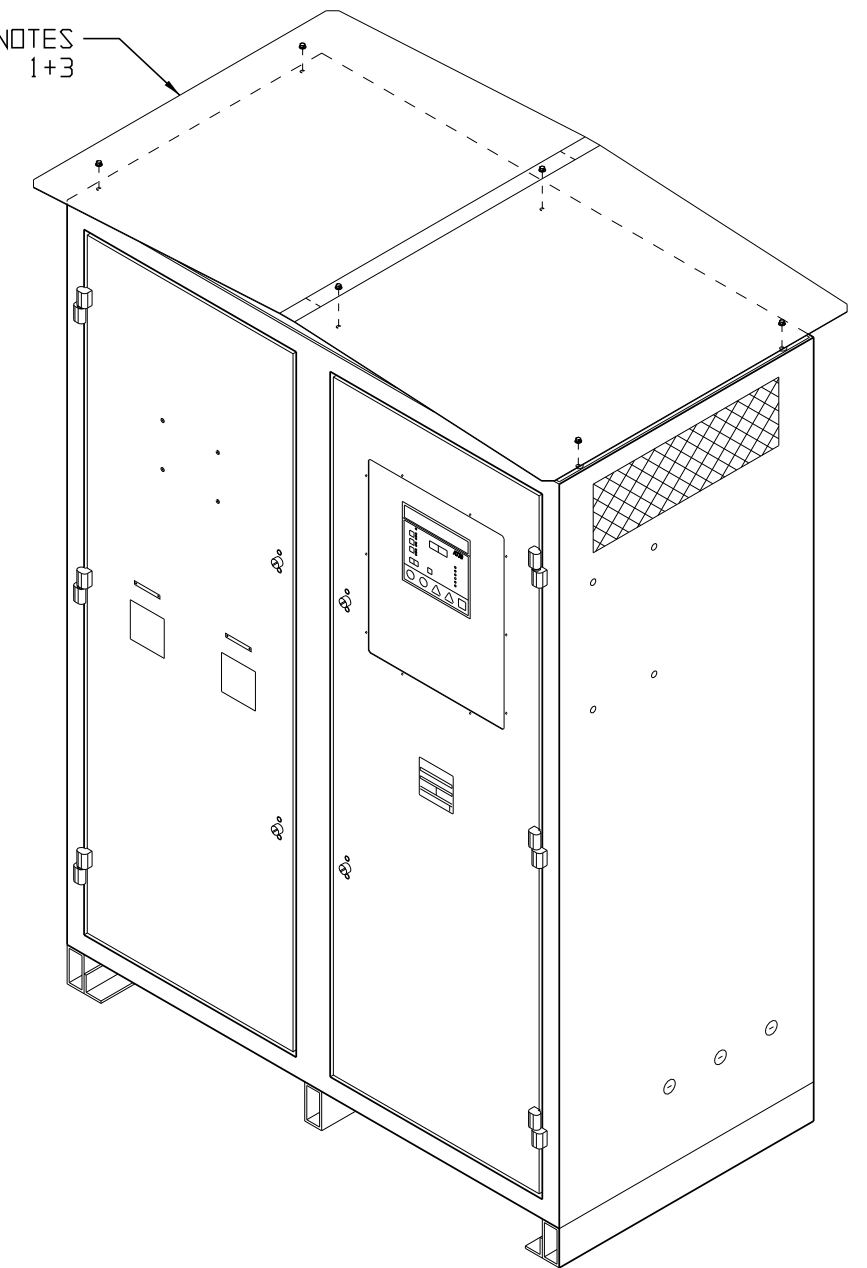

BOTTOM VIEW

NOTES:

- 1) ENCLOSURE IS A TOP-VENTED STEEL CABINET WITHOUT GASKETS. FINISH IS ANSI-61 GRAY EPOXY POWDERCOAT.
- 2) ALLOW 6in / 152mm OF FREE AIR ON ALL VENTED SURFACES (TOP, SIDES & REAR) FOR COOLING.
- 3) NEMA TYPE-2 DRIP SHIELD SUPPLIED AS SHOWN.

DUAL DIMENSIONS in mm

HOLE	DIA.	QTY.	APPLICATION
A	1.313 33.34	6	PRE-FAB CONDUIT KNOCKOUT FOR SML CABLE (BOTH SIDES)

		 THIRD ANGLE PROJECTION			
		DRAWN BY MCR ELECTRONIC APPROVAL SIGNATURES MAINTAINED BY MFG ECN LOG	101623	TITLE AT30 BATTERY CHARGER OUTLINE: STYLE-198 ENCLOSURE W/NEMA-2 DRIP SHIELD	
A	-N/A-	101623	DRAWING No JA0092-05		REV A <b>B</b>
REV	ECN No	DATE	SCALE NTS	SALES No EI0191-05	SHEET 1 OF 1