

WALL STRUCTURE MUST BE SUFFICIENT TO SUPPORT THE FULL WEIGHT OF THE UNIT

FRONT VIEW

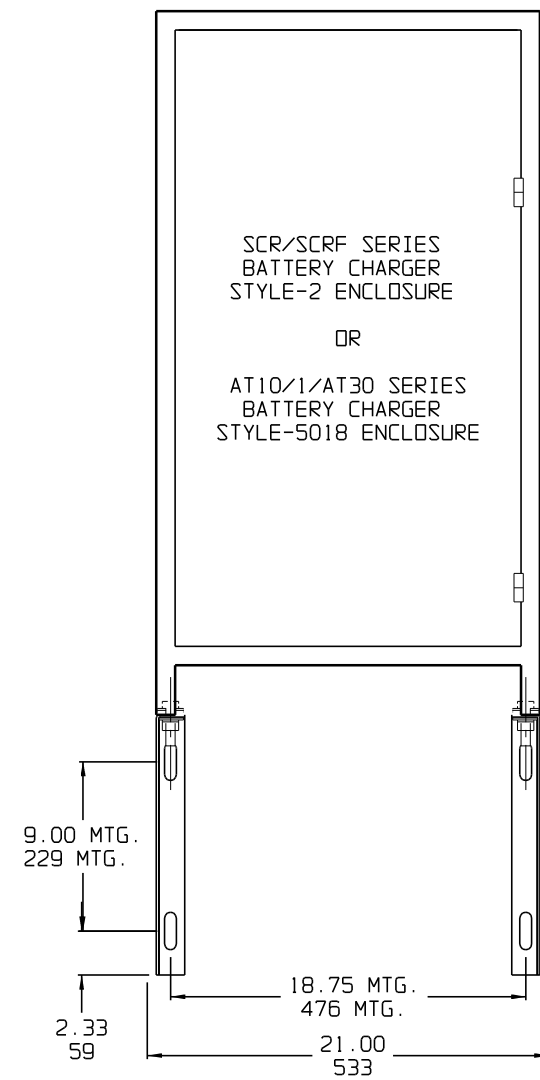

SIDE VIEW

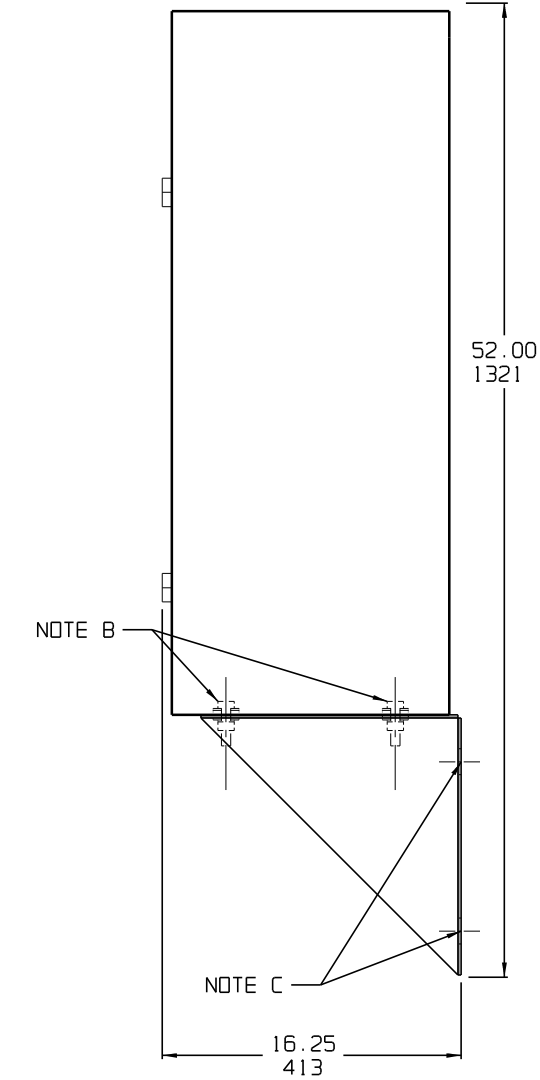

ASSEMBLY PROCEDURE:

- A) SELECTING LOCATION
MAKE SURE THE WALL YOU SELECT TO MOUNT YOUR UNIT TO IS CAPABLE OF SUPPORTING THE WEIGHT OF THE CHARGER, MOUNTING BRACKETS AND ANY OTHER ACCESSORIES THAT ARE PART OF YOUR INSTALLATION.
- B) PROVIDED HARDWARE
THE SUPPLIED 1/2in HARDWARE IS TO BE USED ONLY TO MOUNT THE BATTERY CHARGER ONTO THE WALL MOUNTING BRACKETS.
- C) WALL-MOUNTING HARDWARE SELECTION
THE VERTICAL MOUNTING HOLES ON THE BRACKETS ARE DESIGNED TO ACCOMMODATE 1/2in OR 9/16in BOLTS. THIS HARDWARE IS TO BE SUPPLIED BY THE USER AND IS NOT SUPPLIED WITH THE BATTERY CHARGER AND MOUNING BRACKETS. FOLLOW THE HARDWARE VENDOR'S INSTRUCTIONS WHEN WALL-MOUNTING THE CHARGER/BRACKET ASSEMBLY.

BILL OF MATERIAL:

No.	QTY.	DESCRIPTION
1)	2	WALL-MOUNTING BRACKET (11 GA STEEL)
2)	8	0.5in ZPS FLAT WASHER
3)	4	0.5in ZPS SPLIT LOCK WASHER
4)	4	0.5-13 ZPS HEX NUT
5)	4	0.5-13 x 2.00in ZPS WWTB SCREW

				 THIRD ANGLE PROJECTION		TITLE INSTALLATION INSTRUCTIONS FOR STYLE-2/5018 WALL-MOUNTING BRACKET ACCESSORY (E15008-00)	
				DRAWN BY MCR 120705		DRAWING No JA5063-00	
				APPROVED		REV 0 B	
0	20032	120705		UNLESS OTHERWISE NOTED DIMENSIONS ARE IN INCHES. TOLERANCES ARE:		SCALE NTS PART No JA5063-00 SHEET 1 OF 1	
REV	ECN No	DATE	APP				