



# ATEvo Series Battery Charger EVERYTHING YOU ALWAYS WANTED TO KNOW ABOUT... **GROUNDING**

## OVERVIEW

ATEvo Series Microprocessor-Controlled Float Battery Chargers are equipped (as standard) with a number of different ground fault features. Additionally, certain grounding *options* can be supplied in a given unit, when ordered. This text is an overview of, and a resource of where to get more information on, the following...

## SECTION

- 1) ATEvo Ground Fault Alarms
- 2) Factory-Default ATEvo Ground Fault Sensitivity Set Points
- 3) Setting POS(+) and NEG(-) Ground Fault Sensitivity
- 4) Disabling Ground Detection via Main Ctrl Board (A1) Internal Jumper
- 5) Disabling Ground Detection via Optional Front Panel Toggle Switch
- 6) ATEvo Front Panel Display Zero-Center Ground Fault DC Voltmeter
- 7) Copper Ground Bus Bar (for User Site Wiring)
- 8) Ground Fault Detection and Removal in the Real World

## RESOURCE

- O&SI Section 7.3
- O&SI Section 4.1.2
- O&SI Section 4.3
- O&SI Section 5.5
- [EJ5153-10](#)  
*this sheet*
- [EI5098-##](#)
- [JD5032-00](#)

## 1) GROUND FAULT ALARMS

The ATEvo references site bus voltage, via charger output *inside* of the dc circuit breaker (CB2). A small resistor bridge in the Power Board (A2) measures the voltage *balance*, between pos(+) to ground and neg(-) to ground. Connected to the A2 Power Board via ribbon cable, the ATEvo Main Control Board (A1) firmware logic constantly monitors the ground balance, or imbalance. See also Section 7.3 of the ATEvo O&SI manuals ([JA0102-51](#), [JA0102-52](#), or [JA0102-53](#)).

For greater flexibility and to avoid nuisance alerts, ATEvo features two (2) levels of ground fault alarms (**WARNING** and **CRITICAL**). For both POS(+) and NEG(-), the status of these four (4) alarms are determined by user-adjustable impedance levels. When the ATEvo firmware detects a dc voltage imbalance which surpasses the user-selected levels, a ground fault alarm will occur. See sample screens below.

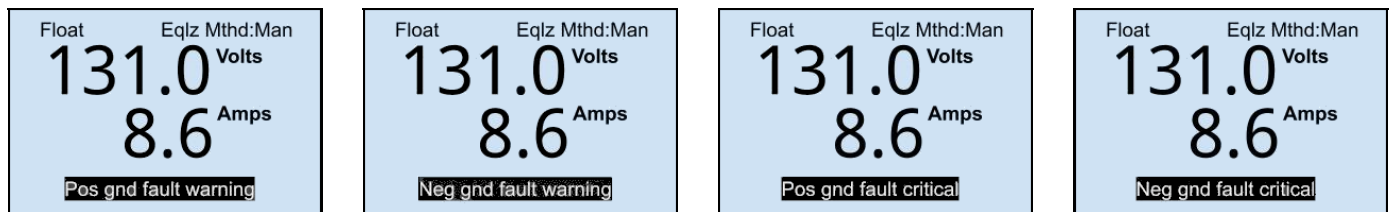

In addition to the front panel display for local (visual) monitoring, ATEvo ground fault alarms can be accessed remotely. By default, ground fault alarms will trigger the ATEvo Common (summary) alarm. This feature can be disabled, see Section 4.6 of the O&SI manual for details. The common alarm relay is accessible on the Main Control Board (A1) terminal block (TB6). See Section 2.6 of the ATEvo O&SI manual for details. If the ATEvo is supplied with an optional Auxiliary I/O Board (A5), individual ground fault alarms can be accessed discretely. See Section 12.1 of the ATEvo O&SI manuals for details.

Finally, the status of ATEvo ground fault alarms are available via DNP3 Level 2 or Modbus protocols, *if* an optional communications module is supplied. Refer to the ATEvo Communications Operation Instructions ([JA0102-54](#)) for details.

## 2) FACTORY-DEFAULT GROUND FAULT SET POINTS

Unless ordered differently, ATevo battery charger models ship from the factory with ground fault *sensitivities* set at **2 kOhm** set for **WARNING** alarm, and **15 kOhm** for full **CRITICAL** alarm. These settings are adjustable (see next section). Settings are available from a low-range value of 10 kOhm to a high-range value of 40 kOhm.

See also Section 4.1.2 of the ATevo O&SI manuals ([JA0102-51](#), [JA0102-52](#), or [JA0102-53](#)).

## 3) SETTING GROUND FAULT SENSITIVITY

The four (4) ground fault *sensitivity* levels, listed in previous Section 2, are user-adjustable in the field. To modify these values, first press the **MENU** button on the ATevo front control panel. Next, use the arrow buttons to highlight **Advanced Settings** on the digital display. Press the **EDIT / ENTER** button, and ATevo will display a scrollable page of parameters.

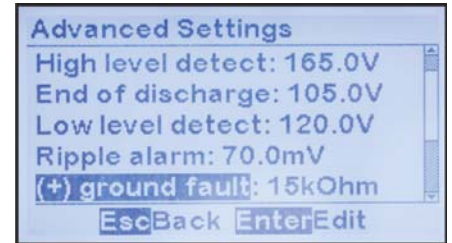

Using the arrow buttons, navigate to the **(+) ground fault** or **(-) ground fault** display, and press **EDIT / ENTER**. Press the up or down buttons to adjust the ground sensitivity (measured in kOhm of resistance). Press **EDIT / ENTER** to save the new setting, or **ESC** to cancel. See also Sections 4.3.1, then 4.3.7 or 4.3.8, of the standard ATevo O&SI manuals ([JA0102-51](#), [-52](#), or [-53](#)).

**NOTICE** To *increase* ground fault sensitivity, lower the depicted kOhm impedance value. To *decrease* the ground sensitivity, raise the kOhm value.

## 4) DISABLING GROUND DETECT VIA MAIN CTRL BOARD JUMPER

Depending on installation, users may wish to temporarily or permanently *disable* the ground detection feature on their battery charger. For security purposes, disabling is not permissible via ATevo front panel controls. To disable ATevo ground detection, follow these steps:

- 1) shut down ATevo, and allow internal voltage potentials to dissipate
- 2) refer to the ATevo standard internal component layout drawings, and identify the Power Board (A2)
- 3) open the door, and locate the Power Board (A2) inside ATevo
- 4) on the Power Board (A2), identify the 3-pin shorting block (JP102) marked "**GROUND DETECT**"
- 5) move the 2-pin jumper from the ENABLED to DISABLED position
- 6) close the door, and restart ATevo with ground detection *disabled*



## 5) DISABLING GROUND DETECT VIA FRONT TOGGLE SWITCH

To disable ATevo ground detection *without* having to access inside unit, a special surface-mounted switch (option p/n EJ5153-10) is available for installation. The toggle switch (SW28) is shipped in the **UP** position, with ground detection enabled. Toggle the switch **down**, to disable ground detection. For further details, refer to the option drawing ([EJ5153-10](#)).



<http://www.atseries.net/PDFs/EJ5153-10.pdf>

## 6) DIGITAL DISPLAY ZERO-CTR GROUND FAULT DC VOLTMETER

In addition to the aforementioned ground fault *alarms*, ATevo is equipped with a software-driven ground fault *meter*. The zero-center dc voltmeter is available via the front panel display, for local (visual) monitoring. The meter utilizes the same voltage *balance* between positive (+) to ground and negative (-) to ground, used by the previous ground alarms.

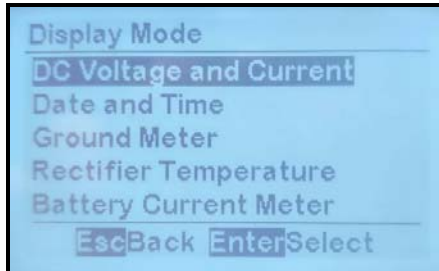

To access the ATevo digital Ground Fault meter, first press the **DISPLAY MODE** button on the control panel. Using the up (▲) or down (▼) arrow buttons, scroll to **Ground Meter**, and press the **EDIT / ENTER** button. Another way to access the ground fault meter is to merely press the right (▶) arrow button to scroll through status screens. Screens will change from **Vdc / Adc**, then to **Time / Date**, and finally to the **Ground Meter** screen.

The ground meter status shown to the *right* would be typical under normal operating conditions. The voltages displayed indicate the reading between each dc leg to ground. The ground symbol is centered between negative (-) and positive (+) legs indicating relative balance, similar to a zero-centered *analog* meter.

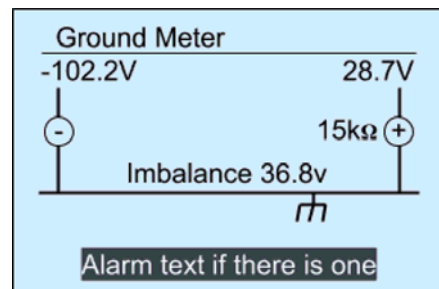
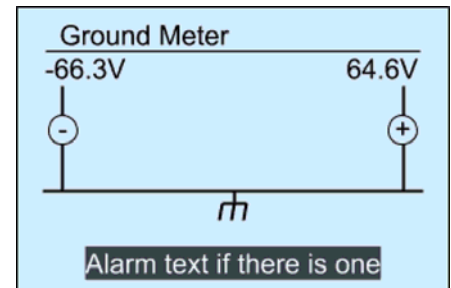

The meter status shown to the *left* represents where a ground fault imbalance on the positive (+) leg of the dc system exists. The ground symbol shifts toward the leg where imbalance is detected. The approximate resistance from ground to that leg will be displayed, as well as the imbalance voltage.

In addition to the front panel display for visual (local) monitoring, the information calculated by the ATevo ground fault meter is also available via DNP3 Level 2 or Modbus protocols, *if* an optional communications module is supplied. Refer to the ATevo Communications Operation Instructions ([JA0102-54](#)) for details.

## 7) COPPER GROUND BUS BAR (for User Site Wiring)



ATEvo chargers are equipped with CU-AL compression type ac terminals, whether on a dedicated I/O panel, or part of the input breaker (CB1). In addition, all models are equipped with a separate compression type **box lug**, properly grounded to the ATevo chassis. Located next to the ac terminals, this user lug is labeled (see image to **left**) per industry-standards.

See **Section 2.4** of the ATevo O&SI manual for making these external ac / ground user connections.

An optional feature for ATevo is the **ground bus bar**. With this accessory a supplemental copper bar is installed into ATevo, and is electrically grounded to the enclosure chassis. In smaller (Style-5054 or Style-5070) enclosures, this ground bar extends through the sidewall panel. The accessible portion of the bar features a hole for user ring lug wiring. No additional hardware is provided. See image to **right**.

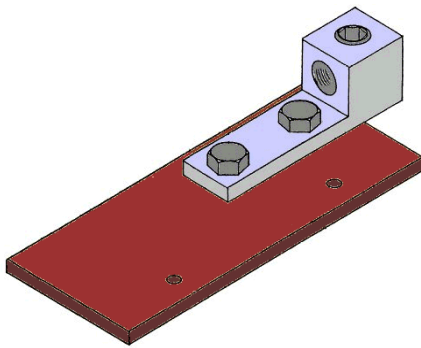

In larger (Style-5030, Style-163, or Style-198) enclosures, the ground bus bar is similarly grounded to the ATevo chassis. However, in these particular models, the copper bar is internally-mounted. For user wiring, an additional CU-AL compression box lug is provided, bolted to the bar. See image to **left**.

The ground bus bar can be ordered with a new ATevo model from the factory. It can also be field installed (p/n [EI5098-##](#)) into a unit after shipment. Inclusion of the optional ground bus bar assembly is identifiable in the ATevo smart part number. See position 24, and identify code ("**G**" - ground bus bar supplied, or "**B**" - for ground bus **and** ac lighting arrestor).

Inclusion of the optional ground bus bar assembly provides a convenient means to tie ATevo to the site building ground. The copper bus bar assembly does **not** positively or negatively affect possible ground fault alarms within the ATevo control circuitry. 😊

<http://www.atseries.net/PDFs/EI5098-XX.pdf>

## 8) GROUND FAULT DETECTION IN THE REAL WORLD

So...the "**GROUND**" indicator LED on the front panel is **ON**. ATevo is most likely working properly. It may have **correctly** detected a ground fault somewhere along the dc bus. 😊 Typically, this does **not** mean the charger is malfunctioning. Now all you must do is identify the **source** of the fault...and eliminate it.

Refer to **Application Note** ([JD5032-00](#)) for a detailed trouble-shooting guide for identifying and eliminating dc system ground faults.

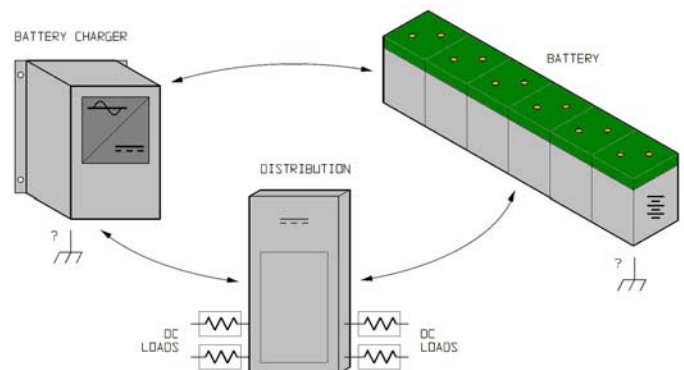

<http://www.atseries.net/PDFs/JD5032-00.pdf>



<http://www.atseries.net/PDFs/JA5124-09.pdf>