

T1 CONNECTION TABLE	
INPUT	JUMPER
120	H1-H3, H2-H5
208	H4-H2 (2)
240	H3-H2 (2)

SHIPPED FROM
FACTORY
TAPPED FOR

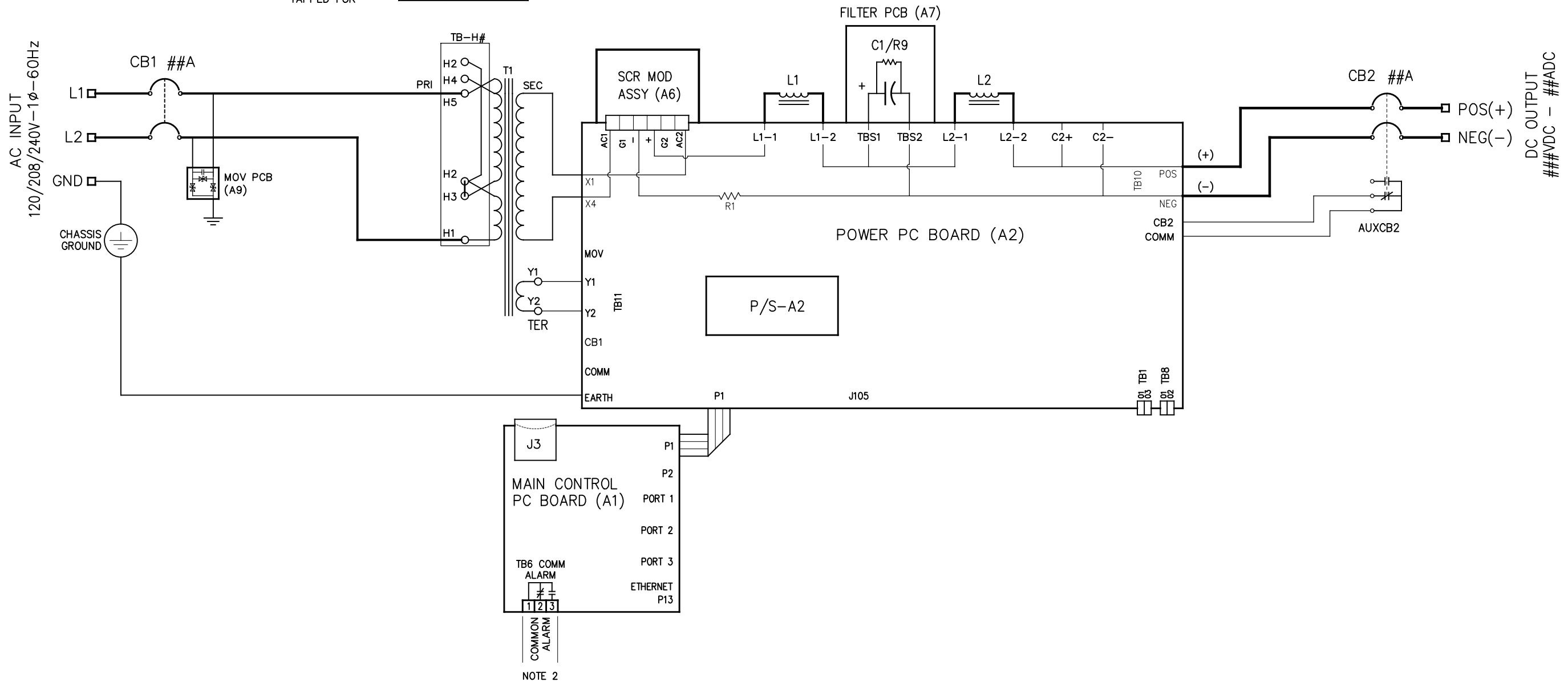

NOTES:

1. FOR PHYSICAL COMPONENT FEATURES OF PC BOARDS (A1, A2, A4, A7 etc.) SEE DETAIL DRAWING JE5253-01.
2. ALL ALARM CONTACTS SHOWN IN NON-ALARM STATE, WITH CHARGER ENERGIZED AND ALARM RELAYS ENERGIZED (FAIL SAFE). ALL ALARM CONTACTS WILL CHANGE STATE WHEN CHARGER IS POWERED DOWN. CONTACT RATING IS: 0.5A @ 125VAC/VDC RESISTIVE.
4. INPUT POWER ISOLATION TRANSFORMER (T1) IS FIELD RE-TAPPABLE FOR 120, 208 OR 240 VAC. SEE TABLE ABOVE.

NOTE 2

REV.	DRN BY	CHK BY	APP BY	DATE	DRN BY	DATE:
D	KJB	MCR	MCR	12/1/2021	KJB	1/21/2021
DESCRIPTION				CHK BY	DATE:	
STANDARD DRAWINGS.				MCR	1/21/2021	
ECN NO. N/A				APP BY	DATE:	
				MCR	1/21/2021	
PROPERTY AND CONFIDENTIAL NOTICE						
ANY REPRODUCTION, PARTIAL OR AS A WHOLE OF THIS DOCUMENT WITHOUT THE WRITTEN PERMISSION OF HINDLE POWER, INC IS STRICTLY PROHIBITED.						



HINDLEPOWER

1075 Saint John Street
Easton, PA 18042-6661
PH 610-330-9000 FAX 610-330-8510
www.hindlepowerinc.com

TITLE
**ATEVO BATTERY CHARGER
SCHEMATIC: STYLE 5070
1φ W/O OPTIONS 6-25A**

B

SCALE DWG No
NTS

JE5254-01

REV SHEET
D 1 OF 1